

20	JOINT TORIQUE / O'RING
19	BAGUE ANTI-EXTRUSION / ANTI EXTRUSION RING
18	VIS DE FIXATION / SCREW (OPTION)
17	PATTE DE VERROUILLAGE / LOCKING DEVICE (OPTION)
16	GOUILLE / PIN
15	RIVET / RIVET
14	PLAQUE D'IDENTIFICATION / FIRM PLATE
13	JOINT D'ETANCHEITE / BODY CONNECTOR SEAL
12	ECROU / NUT
11	ECROU DE FOULOIR / GLAND NUT
10	RONDELLE RESSORT / DISC SPRING
09	POIGNEE / HANDLE
08	FOULOIR / PACKING GLAND
07	GARNITURE D'ETANCHEITE / PACKING RING
06	RONDELLE DE FRICTION / FRICTION RING
05	ELEMENT D'ETANCHEITE / BODY SEAT RING
04	AXE DE COMMANDE / STEM
03	TOURNANT SPHERIQUE / BALL
02	EMBOUT / END CONNECTOR
01	CORPS / BODY
REP	DESIGNATION

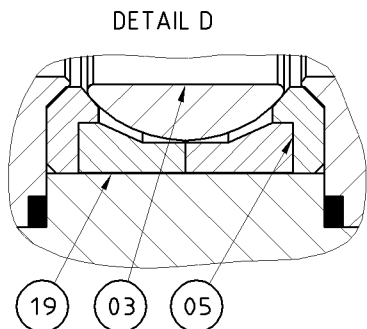
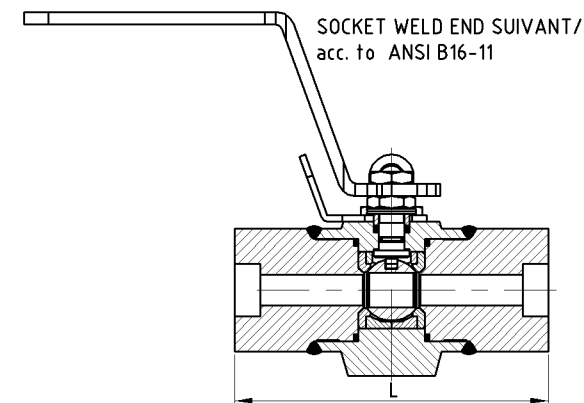
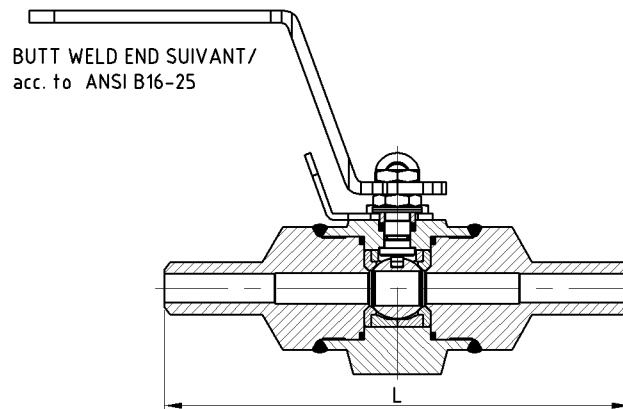

CS 3422
112,114 avenue de Vendôme
41034 BLOIS Cedex
FRANCE

BTC MONOBLOC SOUDE
FULLY WELDED BTC BALL VALVE
Sie 800 - 1500
Class 800 - 1500
BW NPT SW