

BUTT WELD END SUIVANT/ acc. to ANSI B16-25

SOCKET WELD END SUIVANT/ acc. to ANSI B16-11

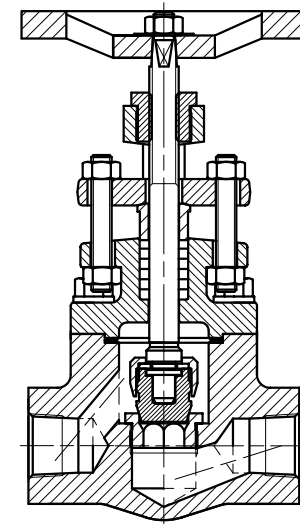

NPT SUIVANT/ acc. to ANSI B1.20.1

Rep.	DESIGNATION
1	CORPS/BODY
2	SIEGE/SEAT
3	CLAPET/DISC
4	TIGE/STEM
5	ECROU DE CLAPET/DISC NUT
6	VERROU DE CLAPET/LOCKNUT WASHER
7	JOINT DE CHAPEAU/BONNET GASKET
8	CHAPEAU/BONNET
9	GARNITURE D'ETANCHEITE/PACKING
10	FOULOIR/GLAND
11	BRIDE DE FOULOIR/GLAND FLANGE
14	TIRANT/GLAND FLANGE STUD
15	ECROU DE TIRANT/GLAND FLANGE NUT
16	DOUILLE/BUSHING
17	VOLANT/HANDWHEEL
18	ECROU DE VOLANT/HANDWHEEL NUT
19	PLAQUE D'IDENTIFICATION/NAME PLATE
20	VIS DE CHAPEAU/BONNET SCREW

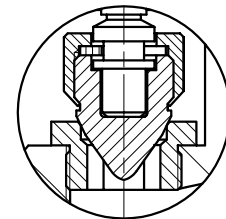

Clapet pointeau en option  
Needle disc option

Matériel conforme à NF M87.412- BS5352  
Matériel in acc. with BS 5352 - NF M87.412



CS 3422  
112,114 avenue de Vendôme  
41034 BLOIS Cedex  
FRANCE

**ROBINET FORGE A SOUPAPE - BW NPT SW**  
**FORGED GLOBE VALVE - BW NPT SW**

Sie 800 -1500 -2500

Class 800 - 1500 -2500

CHAPEAU BOULONNE / SIEGE VISSE  
BOLTED BONNET / RENEWABLE SEAT